

# SAP PLM at KUKA Roboter GmbH



## 1. Introduction

KUKA Roboter GmbH located in Augsburg is a company of IWKA Aktiengesellschaft (Karlsruhe), and considered as global leader in the production of industry robots. Core competencies cover development and production, and also the sales of industry robots, controls, software and linear units.

The business philosophy of KUKA Roboter GmbH includes knowing today what the customers will need tomorrow. Creativity, dynamics and innovation are key to economic success and market leadership. In Germany and Europe, the company is the market leader, and globally ranks third among robots manufacturers.

Robots are increasingly becoming the universal core element of automation. At the same time, an increase in the robots' functionality can be observed. This trend has given rise to new fields

of application beyond the automotive industry. For example, KUKA „Robocoaster“, the first robot world-wide with a licence for passenger transportation.



To even better meet the requirements of a fast developing market and rapid technical progress, KUKA Roboter introduced SAP PLM.



## 2. Initial situation

The engineering and development departments used PDM system CADIM (version 2.3.5), and logistic processes were already integrated into SAP (Release 4.6C). In mechanical engineering an interface to 3D CAD system Unigraphics existed. Unigraphics data were not filed according the Master-Model concept, i.e. without detachment of 3D model and drawing. In CADIM, article masters were managed by bills of material (BOM), and documents by document structures. In addition, a KUKA-specific change management was implemented.

The document management covered approx. 60,000 document versions (meta data for Unigraphics and other document types) and article management approx. 40,000 article master (only current versions) including eventual existing BOM. In Unigraphics approx. 20,000 records existed.

A bi-directional integration existed transferring CADIM master data to SAP, and reading information from SAP.

## 3. Why SAP PLM?

CADIM support phased out, and thus initially the application of EignerPLM as subsequent program was evaluated. However, the fundamental challenge of data redundancy and interface maintenance remained.

Time and again, holding identical data in two different systems (CADIM and SAP), and the transfer via interface lead to inconsistencies and problems only to be solved with considerable effort. Moreover, engineering and purchase departments had to login to two different systems to get a complete overview over a part or an assembly.

# SAP PLM at KUKA Roboter GmbH



By merging all product data into a single system redundancies are eliminated. All company departments – sales & marketing, engineering, merchandise planning, production, and purchase – work with the same data.

That way, misunderstandings and resulting errors are omitted.



At KUKA Roboter, SAP was already implemented as a strategic product, and consequently the implementation of SAP PLM as continuous PLM solution was considered.

Prerequisite for switching from CADIM to SAP PLM was the existence of a reliable integration of SAP and Unigraphics. Initial inquiries were already made approx. two years before the project started. Considered was the integration “mySAP PLM Integration for Unigraphics” (Version 2.1) provided by SAP and developed by DSC Software AG (herein after called DSC).

Next to the direct integration of Unigraphics and SAP, the decisive factor was continuous processes mapping the lifecycle of the product and its components.



The choice was made for DSC as partner for the project implementation because DSC was to show experience in the CADIM and SAP environments, including the migration of stock data from CADIM to SAP PLM.

## **4. Project process and results**

The project divides into the following phases:

- Test installation of mySAP PLM Integration for Unigraphics
- Concept phase and process definition
- Implementation and realization
- Migration of stock data
- Productive start

### ***4.1. Test installation of mySAP PLM Integration for Unigraphics and Kick-Off***

After implementing the integration by DSC on a SAP test system at KUKA, the user verified whether the integration meets the general and KUKA-specific requirements of functionality, stability and performance. The result was positive leading to the final implementation of SAP PLM. The project kick-off took place in April of 2003. Company internal requisites made a productive start in December of 2003 imperative.

### ***4.2. Integration of Unigraphics and SAP***

In Unigraphics the Master-Model concept was introduced. Decisive here was the expected performance gain on loading large assemblies. In addition, the Master-Model concept is recommended by DSC and EDS (Unigraphics) as a future-proved

# SAP PLM at KUKA Roboter GmbH



method, especially concerning the following use of 3D data in several systems (e.g. production systems).

In SAP, the document types 3D-Model and



Drawing were created including a standard class with additional describing characteristics. Drawings included the creation of page-specific characteristics holding values not only for the drawing itself, but also single values for single pages.

The data transfer between SAP and Unigraphics is bi-directional. The drawing frame is page-specific completed by attributes, and automatically updated after document change in SAP. From within Unigraphics CAD-specific data – for example, the drawing format – is transferred to SAP.

The integration proved to be stable, and also the performance met the expectations. The performance increase on loading large assemblies is approx. 30%.

The Object Manager, developed by DSC, offering the engineer a convenient graphical user interface desktop stands the test. In addition to the standard delivery, the following DSC modules were implemented:

- ++change management
- ++data exchange manager (export-/import manager)
- ++classify (classification)
- ++convert (conversion of original files)



## ***4.3. Integration of processes***

The processes already implemented in CADIM were reviewed in detail. Due to different methods in CADIM and SAP the processes were completely redesigned.

In document management the status networks existing in SAP and continuous version management were implemented. Status networks for material master and change numbers were realized by programming. Status networks and the automatic assignment of revisions for materials ensured that changes with existing products enter the company process in a controlled way. For that the SAP change number was extended by KUKA-specific fields, and provided with additional supportive functions (e.g. status change material and document via mass processing).

SAP arranges for a fundamental distinction of change request and change task. However, this rigid distinction was disclaimed, instead request and task management was mapped by the change number status network. The advantage of this solution is better handling by the user.

## ***4.4. Support of change management by SAP-workflow and KUKA change message***

Status changes for materials, change numbers or documents represent a stage forward in the lifecycle of a product, and trigger following action in the company.

In order to system-based inform affected company departments, the SAP workflow was introduced. On defined status changes, specific user automatically receive a message.

In order to distribute changes to suppliers, the KUKA tool "Change Message" was programmed allowing to "bundle" a package holding all relevant original files and material BOMs (also multi-level) for targeted change numbers or material. The tool is also used for KUKA in-house messages. The data is provided within the file system.

This omits the labored copying of original files via document info records, and the manual creation of single BOMs. Moreover, change message include information about open purchase orders and active supplier.

## **4.5. Filing of original files and conversion**

The filing of original files takes place via SAP service KPRO (Knowledge Provider) on a separate content server. In operative use, the server proved very reliable with high performance. Since the SAP GUI is a default feature of KUKA standard PCs, worldwide each user is able to access engineering data – the respective authorization given.

For converting Unigraphics files to neutral formats, such as, JT, TIFF or PDF

a separate conversion server was trouble-free set up and launched by DSC.

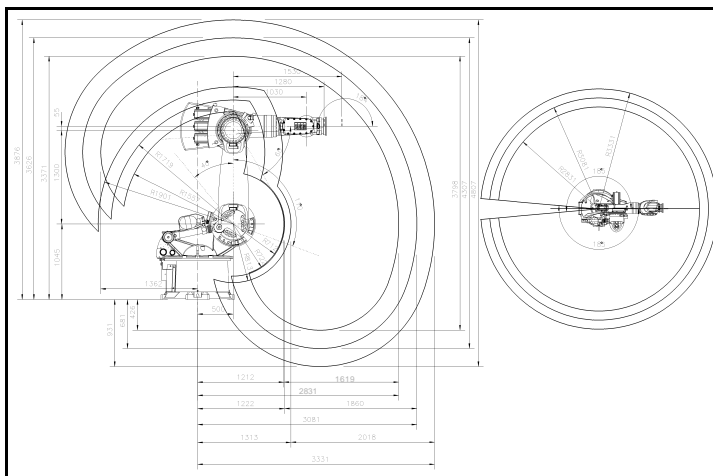

## **4.6. Migration of stock data**

The migration of meta data was successful after some work in SAP. The clean-up was necessary due to inconsistencies between CADIM and SAP.

In the course of the migration of Unigraphics data some unforeseen technical problems happened. Contingent on the introduction of the Master-Model concept each part had to be data-related changed. Some of the problems were circumvented

# **SAP PLM at KUKA Roboter GmbH**



by changing the migration process, the rest, however, has to be eliminated by re-working on next part editing.

However, the overall migration concept was never questioned because the advantages of the implemented solution continued to be decisive.

## ***4.7. On-schedule productive start***

The productive start early December was successful and on-schedule. It was accompanied by training measures for the user who for the first time worked with SAP.

Parallel to the productive start, DSC delivered one week of local user support. In spite of differences in philosophy and procedures between CADIM and SAP, engineers quickly found their ways in the new environment, and successfully handled the systems.

After the productive start, some non-time critical re-working was necessary.

## **5. Summary and outlook**

In SAP PLM all departments – from engineering to spare part management / service – work with the same data. This sharpened the awareness for the lifecycle of a product. This already became obvious in several department-spanning discussion.

Further expansion of SAP PLM considers the introduction of a plot management tool and the introduction of mySAP PLM Integration for Unigraphics Version 3.0.